



CRE-2110 Electra-Ride III™ Stairway Elevator
Technical Specifications

rev: 10/5/2009
ILS-00905

MODEL NUMBER: CRE-2110 & CRE-2110C
U.S. F.D.A. CLASSIFICATION: Class II,
CLASSIFICATION NUMBER: 890.5150

PERFORMANCE STANDARDS: USA Food & Drug Administration: None
ANSI/ASME: A18.1-2008 Safety Standards for Platform Lifts and Stairway Chairlifts
ANSI/ASME: A17.1-2004 Commercial (PART XX) & Private Residence Inclined Lifts
(PART XXI)
CSA C-US Listed: File Number 208135

APPLICATIONS: Straight staircases, straight with top and bottom overruns and straight with intermediate landing. Variety of flat, spiral, and custom staircase configurations on both the inside and outside of the staircase.

RATED LOAD: 400 lbs maximum

NUMBER OF PASSENGERS: 1

POWER SOURCE: 24 Volt DC comprised of 2ea 7amp/hr 12 volt sealed maintenance-free lead acid batteries. On/Off power switch to prevent battery drain over lengthy storage periods.

CHARGER: 110 Volt AC 1.5 Amp, 24 Volt DC 2 Amp continuous monitoring, full primary cut off.

DRIVE: 24 Volt DC direct drive gear-motor, 2 pole rated .68 HP, 58:1 right angle self-locking worm gear box, 41.5 RPM on the output shaft of the gear box.

FINAL DRIVE: Integrated 8dp gear rack on rail with a spur gear on the gearbox output shaft.

MOTOR CONTROLLER: Custom 24 Volt DC PWM controller with acceleration ramping.

BRAKING: dynamic motor braking through the motor controller, self locking worm gear box, and electro-mechanical motor brake.

**Bruno Independent Living Aids, Inc., 1780 Executive Drive, P.O. Box 84, Oconomowoc, WI 53066
Phone (800) 882-8183 Fax (262) 953-5501**

Any reproduction or other use of these materials without written permission of Bruno Independent Living Aids, Inc. is expressly prohibited. Bruno Independent Living Aids, Inc. reserves the right to modify or make changes to these specifications at any time without notice.

REMOTE CONTROL: Custom 2.4GHz wireless “CALL/SEND” control with interference suppression. Momentary switching requires a user to continuously hold button to control unit. Optional keyed controls

STANDARD CONTROL: 3 positions, momentary rocker switch requiring user to continuously hold rocker switch to control unit, switch mounted under armrest. Optional keyed control.

MOUNT: Either side of stairway, the unit is easily installed on either side of the staircase.

SUPPORTS: Clamps anchored to stair tread, normal rail position is 2.5” above step nose. Number of clamps dependent on the length of rail.

ANGLE: Adjustable from 0 to 45 degrees standard, specials to 50 degrees.

SPEED: Maximum top speed is 25 feet per minute. Actual speed will vary depending on rider weight and angle of incline.

LENGTH OF TRACK: Custom lengths to 50’

TRACK CONSTRUCTION: 5/16” mild steel welded shape, covered gear rack welded to rail. Joint with welded on side clamp blocks at each rail joint.

TRACK LOCATION: Track is designed to the contour of the stairway and can fit to within 7”- 8” of the wall or obstruction.

TRACK EXTENSION: Standard track extension is approximately 6.5” past the top step nose and 18-20” past the bottom step nose.

FOOTREST: Folding footrest with safety sensor panel and handle actuator.

SEAT: Padded, Folding & Swiveling with stops at 45 (bottom), 0 (forward), 60 (top), and 90 (top). Multiple position seat height adjustments.

ARMRESTS: Fixed to seat frame. Armrest can be individually rotated towards seat back for smaller profile when not in use and easier transfers. Armrests have 4” width adjustment

SAFETY EQUIPMENT: 1) Seat swivel switch allows operation only when chair is in center Position.

2) Carriage & Footrest safety switches

3) Retractable seat belt

4) Charging light (green) on carriage

Charging light (amber) at each end of rail

5) 30 amp manual reset breaker on the motor control circuit

6) 5 amp fuse on the control circuits

7) Final end stop bumper at each end of the rail

8) Final limit switch

9) Full diagnostic user interface PC Board

10) Optional overspeed safety brake

POWER OUTAGE: Unit should have 8 to 20 round trips on a full battery charge

**Bruno Independent Living Aids, Inc., 1780 Executive Drive, P.O. Box 84, Oconomowoc, WI 53066
Phone (800) 882-8183 Fax (262) 953-5501**

Any reproduction or other use of these materials without written permission of Bruno Independent Living Aids, Inc. is expressly prohibited. Bruno Independent Living Aids, Inc. reserves the right to modify or make changes to these specifications at any time without notice.

(variance caused by angle, length of run, ambient temperature and rider weight).
Batteries should last between 28 and 36 hours after the power is disconnected.

WEIGHT OF UNIT: 100lbs carriage and drive, 50 lbs seat and foot rest, and 16 lbs. per foot rail weight.

TESTING PERFORMED:

- 2) Battery charger meets UL 1236 battery charger specifications and has been Independently tested.
- 3) The self locking gear box was statically tested with 3200 lbs (8X rated load) on a 45 degree rail for 5 minutes with no carriage movement. This test was performed at the manufacturer's location.
- 4) Repetitive tests were run to determine power outage cycling.
- 5) Electrical discharge to ground testing performed for FDA 510(k).

OPTIONS:

1. Keyed remote call/send controls,
2. Keyed Controls on chair arm,
3. Commercial package w/overspeed safety brake
4. Power Swivel seating
5. Power actuated foot rest
6. Midstop park positions charging at intermediate landings
7. Upper and lower landing park positions
8. Extra large seat
9. Extra large footrest platform (manual and powered)

**Bruno Independent Living Aids, Inc., 1780 Executive Drive, P.O. Box 84, Oconomowoc, WI 53066
Phone (800) 882-8183 Fax (262) 953-5501**

Any reproduction or other use of these materials without written permission of Bruno Independent Living Aids, Inc. is expressly prohibited.
Bruno Independent Living Aids, Inc. reserves the right to modify or make changes to these specifications at any time without notice.

TECHNICAL DATA/SPECIFICATION

MODEL: CRE-2110 ELECTRA-RIDE III
 RATED LOAD: 400 LBS, ONE PASSENGER
 POWER SOURCE: 24 VOLT DC COMPRISED OF (2) 7 AMP/HR
 12 VOLT SEALED BATTERIES
 110 VOLT AC 1.5 AMP, 24 VOLT DC 2 AMP
 CONTINUOUS MONITORING CHARGER.
 DRIVE: 24 VOLT DC DIRECT DRIVE GEAR-MOTOR, 2 POLE
 RATED .68 HP, 58:1 RIGHT ANGLE SELF LOCKING
 GEARBOX, 41.5 RPM NO LOAD RPM OUTPUT SPEED.
 SUSPENSION: RACK & PINION - INTEGRATED 8DP GEAR RACK
 ON RAIL WITH A SPUR GEAR ON THE OUTPUT
 SHAFT OF THE GEAR BOX.
 BRAKING: DYNAMIC MOTOR BRAKING THROUGH THE MOTOR
 CONTROLLER; SELF LOCKING WORM GEAR, AND
 ELECTRO-MECHANICAL MOTOR BRAKE.
 CONTROLS: CONTINUOUS PRESSURE ROCKER SWITCH LOCATED
 ON THE ARM REST AND WALL MOUNTED CALL/SEND
 CONTROLS LOCATED AT BOTH THE TOP AND BOTTOM
 LANDINGS.
 ANGLES: 0 TO 45 DEGREES (SPECIALS UP TO 50 DEGREES) RIGHT
 OR LEFT HAND ORIENTATIONS.
 FINAL LIMIT SWITCH STANDARD
 OPTIONS:
 1) KEYED CALL/SEND CONTROLS,
 2) KEYED CONTROL ON CHAIR,
 3) COMMERCIAL PACKAGE W/OVERSPEED SAFETY BRAKE.

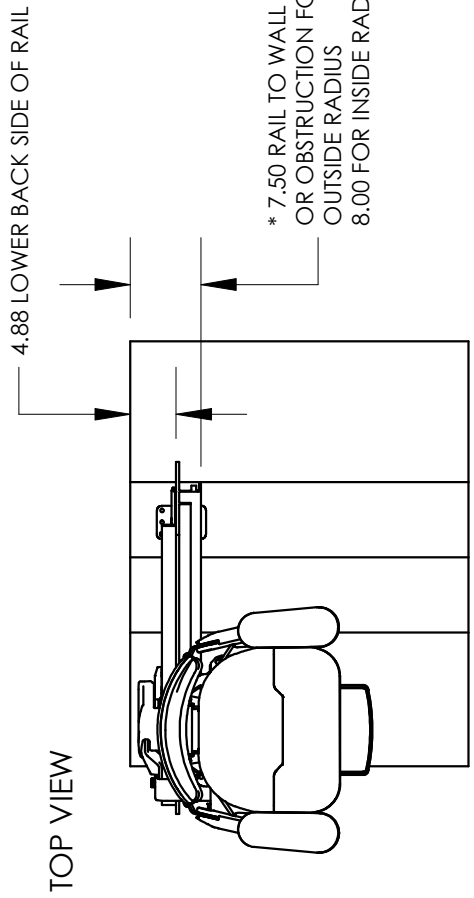

TOP VIEW

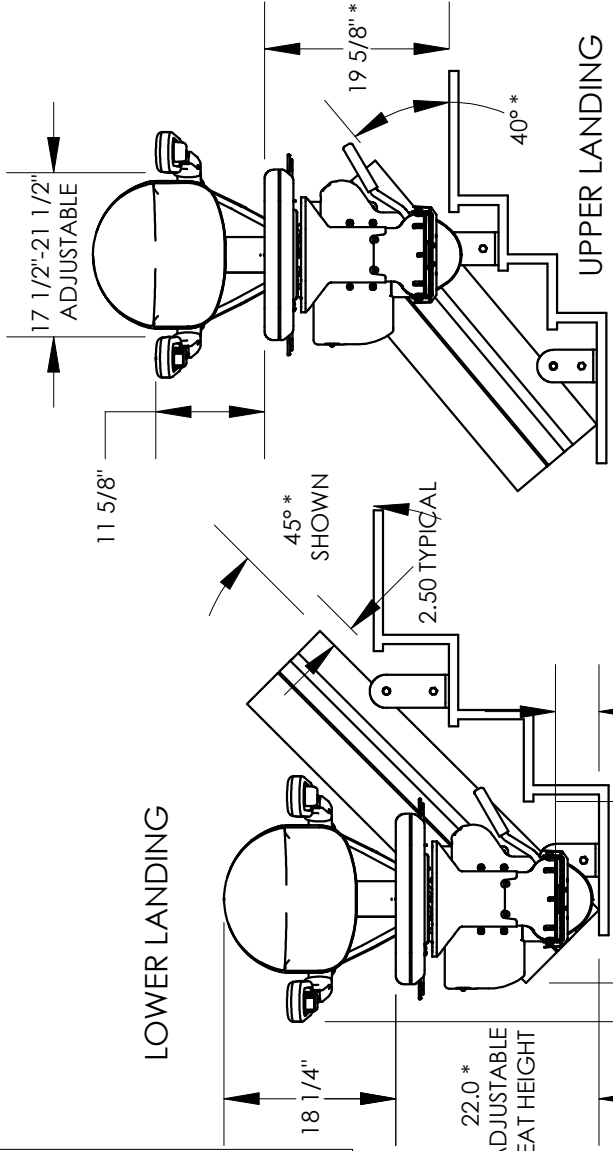

ELEVATION VIEWS

1780 Executive Drive
 P.O. 84
 Oconomowoc, WI 53066
 Tel 800-882-8181
 Fax 262-953-5501
 www.bruno.com

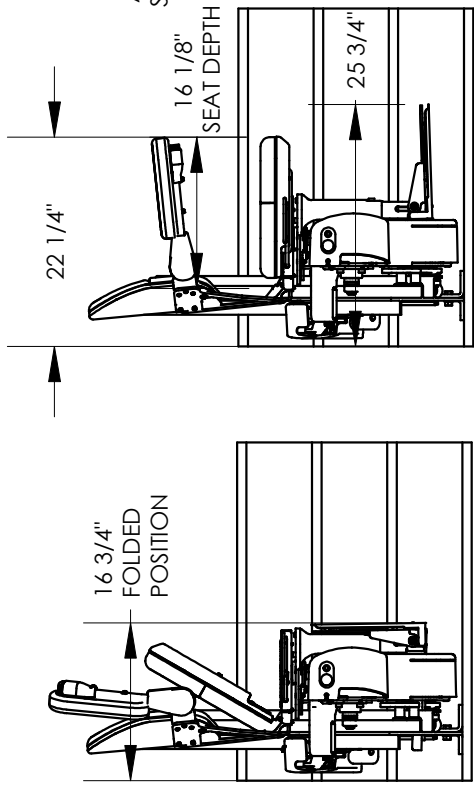

SIDE VIEWS

DIMENSIONS WITH * ARE APPROXIMATE.
 THESE DIMENSIONS MAY VARY BASED ON
 THE SLOPE, RISER HEIGHT, AND CUSTOM
 SEAT ADJUSTMENTS MADE FOR THE USER.

CRE-2110 TECH DRAWING

